

Prosonic S Transmitter via HART to the PlantPax Process Automation System

System using a ControlLogix 1756 HART Analog Input Module



PlantPax
Process Automation System

Topic	Page
Preferred Integration	2
Application Overview	4
System Details	8
Installation	9
Configure the HART Input Module	13
Configure the Prosonic S Transmitter	15
Visualization	24
Performance Considerations	30
Additional Resources	31

Preferred Integration

Rockwell Automation and Endress+Hauser have strengthened their strategic alliance to provide complete process automation solutions that use best-in-class instrumentation, software, and control systems.

There are hundreds of different components in a typical plant: controllers, remote I/O, electrical drives, safety equipment, and sensors. Each must be integrated, configured and optimized during start-up and operation. Recognizing the challenges this creates, Rockwell Automation and Endress+Hauser are focused on providing you with scalable, off-the-shelf solutions.

Endress+Hauser competence

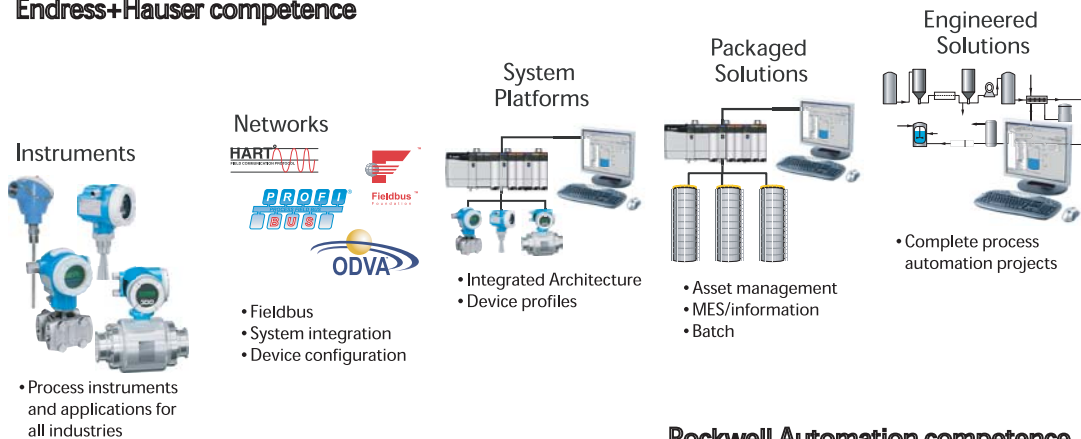

Rockwell Automation competence

To supply robust system solutions, Rockwell Automation pre-tests many third-party manufactured HART, FOUNDATION Fieldbus, and Profibus field devices in the system test laboratory for compatibility with the Rockwell Automation PlantPAx process automation system. Each field device is connected to the PlantPAx system and is subjected to interoperability testing procedures similar to operating procedures in your plant. The results of each field test are recorded in a test report for integration planning purposes.

For Endress+Hauser field devices, an additional step provides an “Integration Document” and “Interoperability Statement” for each tested instrument. The Integration Document provides information on installation, configuration, startup, and operation of the integrated system. The Interoperability Statement is assurance that the Endress+Hauser field device meets PlantPAx system interoperability performance measures, as jointly established by Rockwell Automation and Endress+Hauser and verified through completion of common test procedures performed by either company. Both the Integration Document and Interoperability Statement ensure a no risk solution highlighted by ease of integration and optimum performance.

The overall mission of the alliance is to provide you with proven solutions that combine field instrumentation with fieldbus networks, such as HART, FOUNDATION Fieldbus, and Profibus networks, with asset management capabilities and Rockwell Automation's system capabilities to provide a total engineered solution.

Through preferred integration and support of increasing requirements for plant-wide control, the alliance offers the following benefits:

- Reduced integration costs throughout engineering, commissioning, and start-up
- Optimized plant availability and output
- Ensured product quality and consistency
- Optimized traceability to meet regulatory demands
- Predictive maintenance through intelligent instruments

For new construction, process improvements at an existing plant, or operating cost reductions, the alliance delivers the following:

- Integration reduces risk, reduces integration costs, and protects investment with assured interoperability. Both companies believe open systems and standardized interfaces bring maximum benefits.
- Advanced diagnostics with plant-wide support offers better visibility of plant health and easier access to instrument diagnostics, which leads to faster troubleshooting and improves decision-making.
- Collaborative lifecycle management to design, engineer, and startup systems faster. This collaboration increases productivity, manages information about instrumentation assets, optimizes plant assets, and results in a complete lifecycle management solution.

***Plant*PAx**
Process Automation System

Application Overview

This document provides a step-by-step approach to integrating an Endress+Hauser Prosonic S transmitter for ultrasonic sensors into a Rockwell Automation PlantPAx process automation system.

This Section	Describes
Application overview	Details about the field instrument and control system.
System details	Specifications on the required hardware and software components.
Installation	How to: <ul style="list-style-type: none"> • Connect the measurement instrument to the HART I/O module. • Connect a HART handheld device.
Configuration	How to: <ul style="list-style-type: none"> • Configure the HART I/O module. • Configure the measurement instrument and manage parameters.
Visualization	How to implement and configure a graphical display of device information.

The ControlLogix platform provides a full range of input and output modules to span a wide variety of applications. The ControlLogix architecture uses producer/consumer technology, allowing input information and output status to be shared by all ControlLogix controllers in the system.

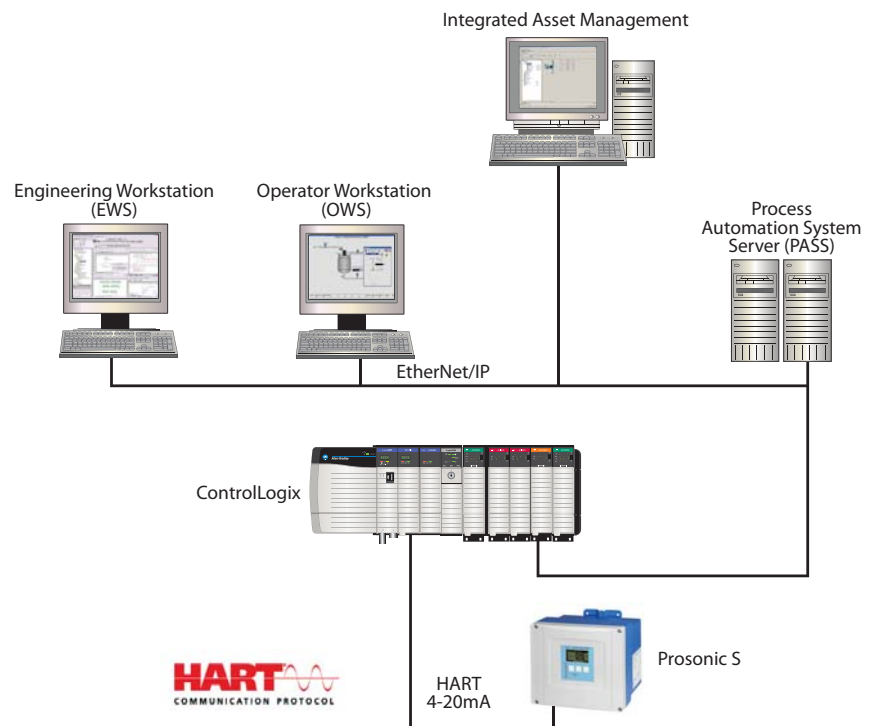

This integration document assumes you have a working knowledge of ControlLogix systems. For more details regarding the equipment and tasks described in this document, see [Additional Resources](#) on page 31.

Prosonic S Transmitter

The Prosonic S transmitter provides non-contact level measurement of fluids, pastes sludge and powdery to coarse bulk materials and flow measurement in open channels and measuring weirs with 1 or 2 ultrasonic sensors. Prosonic S offers the following:

- Time-of-flight correction via integrated or external temperature sensors.
- Simultaneous measurement of level and flow in a stormwater overflow basin with only 1 sensor.
- Pre-programmed pump control routines.
- Automatic detection of the sensors FDU9x.
- The sensors of the former series FDU8x can be connected.

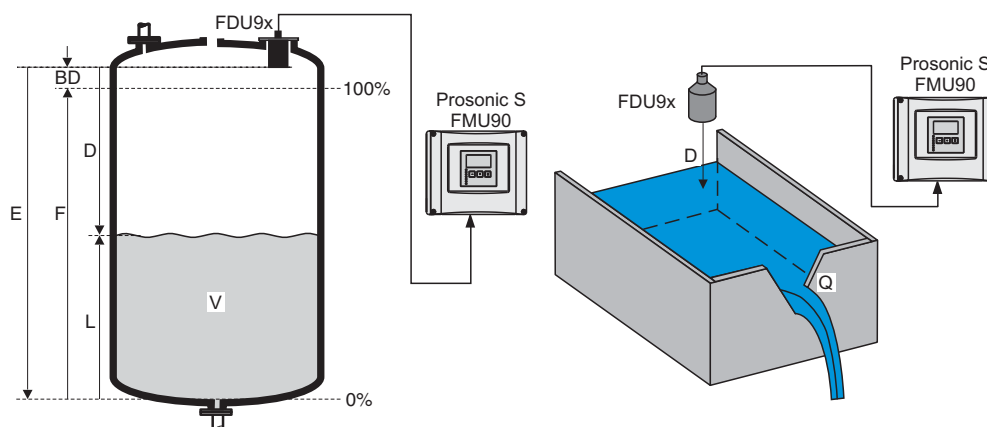

Item	Description
BD	Blocking distance
D	Distance from sensor membrane to fluid surface
E	Empty distance
F	Span (full distance)
L	Level
V	Volume (or mass)
Q	Flow

The sensor transmits ultrasonic pulses in the direction of the product surface. There, they are reflected back and received by the sensor. The transmitter Prosonic S measures the time t between pulse transmission and reception. From t (and the velocity of sound c) it calculates the distance D from the sensor membrane to the product surface:

$$D = c \cdot t/2$$

Measured Variables

From D results the desired measuring value:

- Level L
- Volume V
- Flow Q across measuring weirs or open channels

Signals from Instrument to Control System

Output Signal	Details
Current Output	<p>4...20 mA with HART 0...20mA without HART USS = 200 mV at 47...125Hz (measured at 500Ω) Ueff = 2,2 mV at 500 Hz... 10 kHz (measured at 500Ω)</p> <p>For Setting 4...20 mA, selectable</p> <ul style="list-style-type: none"> • 10% (3,6 mA) • 110% (22 mA) • HOLD (last current value is held) • User specific <p>For Setting 0...20 mA</p> <ul style="list-style-type: none"> • 110% (21,6 mA) • HOLD (last current value is held) • User specific <p>Maximum 600 Ω, influence negligible</p> <ul style="list-style-type: none"> • USS = 200 mV at 47...125Hz (measured at 500Ω) • Ueff = 2,2 mV at 500 Hz...10kHz (measured at 500Ω)
Output Damping	Freely selectable, 0...1000 s
Relay Outputs	<p>DC voltage: 35 VDC, 100 W AC voltage: 4 A, 250 V, 100 VA at cos = 0.7</p>

Control System

The control system includes these components:

Component	Description
Controller	The ControlLogix controller is a modular, high performance controller, that uses RSLogix 5000 programming software to configure, program, and monitor a system. The ControlLogix controller is certified by TUV for SIL 1 and SIL 2 applications.
HART I/O module	The ControlLogix HART analog I/O module converts to or from 4...20 mA analog signals and the digital values used in the ControlLogix controller. The I/O module automatically collects dynamic process data from the HART field instrument. The I/O module also bridges HART messages from CIP clients to HART field instruments.
Programming software	RSLogix 5000 programming software is the design and configuration tool for HART I/O that includes status and diagnostic information. The software has predefined data structures for status and configuration. A common tag database in the controller allows HMI development to directly reference I/O and controller tags without the need to manage another database in your HMI software.
Operating software	FactoryTalk View Site Edition software is an HMI software program for monitoring, controlling, and acquiring data from manufacturing operations throughout an enterprise. A generic display provides a graphical representation via faceplates of the field instrument connected to the HART input module.
Asset management software	FieldCare software is Endress+Hauser's plant asset management software for configuring and managing the intelligent field devices in your plant. <ul style="list-style-type: none"> • Supports EtherNet, HART, and Profibus networks. • Supports all Endress+Hauser field instruments. • Integrates third-party devices, such as actuators, I/O systems, and sensors that support the FDT standard. • Ensures full functionality for all devices with DTMs. • Offers generic profile operation for any third-party fieldbus device that does not have a vendor DTM.

HART Handheld Device (Optional)

The Field Xpert handheld device is an industrial PDA with integrated 3.5" touch screen based on Windows Mobile. It communicates with a HART device wireless via the optional VIATOR Bluetooth modem connected to a HART device point-to-point. The PDA meets the needs and requirements of the process industry with protection from static electricity, water and dust with shockproof housing. It is available in different versions for operation both inside and outside of explosion hazardous areas.

System Details

These components and specifications are recommended for preferred integration.

Hardware Components

Component	Catalog Number	Details
Prosonic S transmitter	FMU90-R11CA111AA1A	Firmware revision 2.00
ControlLogix controller	1756-L63 series B	Firmware revision 16.20
ControlLogix HART input module	1756-IF8H	Firmware revision 1.2 1756-TBCH, 1756-TBS6H 36-position, cage-clamp RTB 1492-AIFM8 IFM with 1492-ACABLE-UD
Field Xpert handheld device (optional)	SFX100	Version 1.00

Software Components

Component	Catalog Number	Details
RSLogix 5000 Enterprise Series programming software, Professional edition Includes: <ul style="list-style-type: none"> • RSLinx Classic software • RSLinx Enterprise software 	9324-RLD700NXENE	Version 16.03
FactoryTalk View Site Edition (SE) software	9701-VWSXXXXXENE	Version 5, CPR 9
FieldCare Standard Asset Management software (optional) Includes: <ul style="list-style-type: none"> • DTM library 	SFE551	Version 2.05
RSLinx Communication DTM software (optional)	1756-Backplane	Version 1.0.0

For specifications of the engineering workstation (EWS) and operator workstation (OWS), see the [Integrated Architecture for Process Control System Recommendations Manual, publication PROCES-RM001](#)

Installation

The following information is a summary of the installation procedures. See [Additional Resources](#) on page 31 for complete installation instructions, including warnings.

Connect a Prosonic S Transmitter

Following are the terminals of the Prosonic S. The terminals depicted in grey are not present in every instrument version.

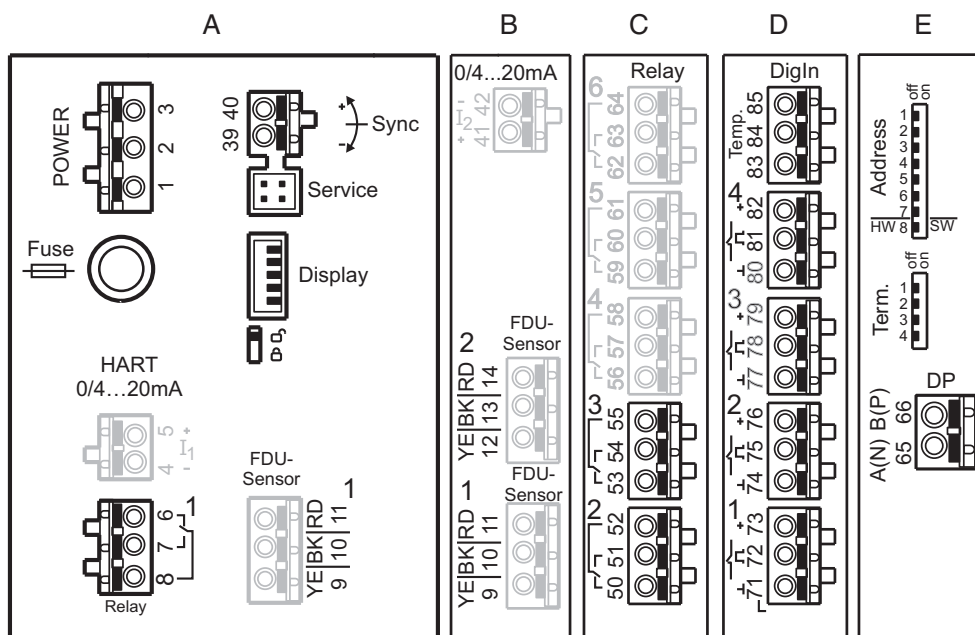

Item	Description
A	Basic terminal area
B-E	Optional terminal areas (present if the respective option has been selected in the product structure).

Sensor Connection

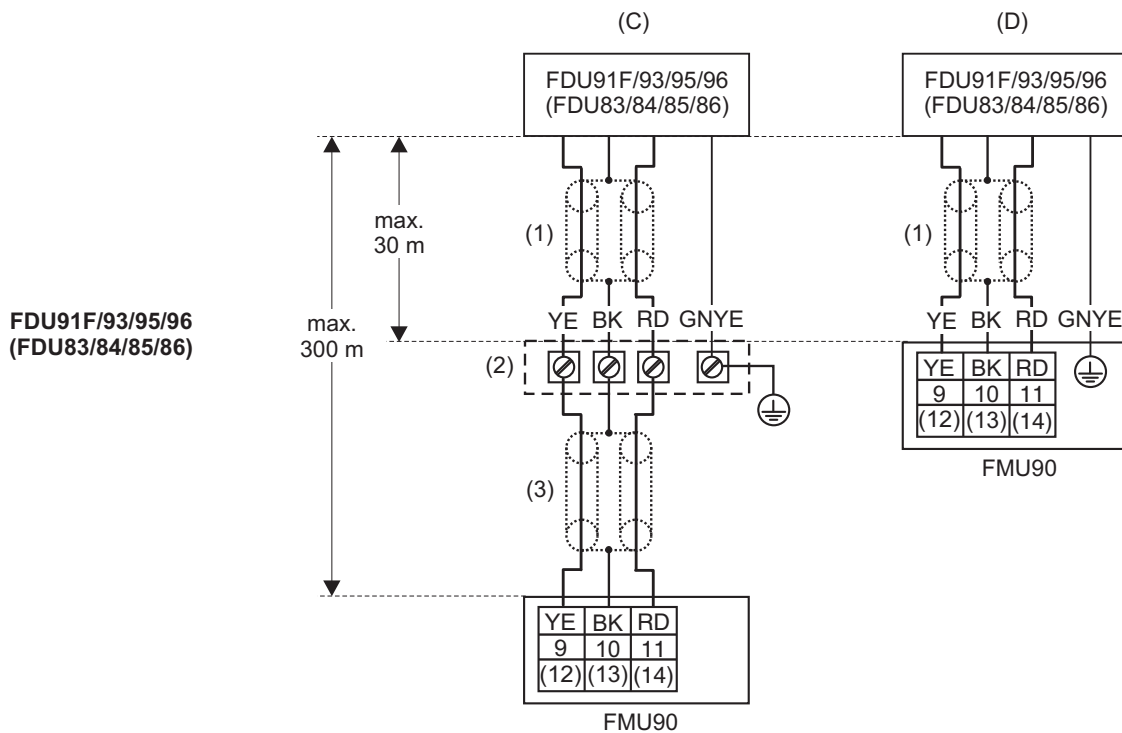
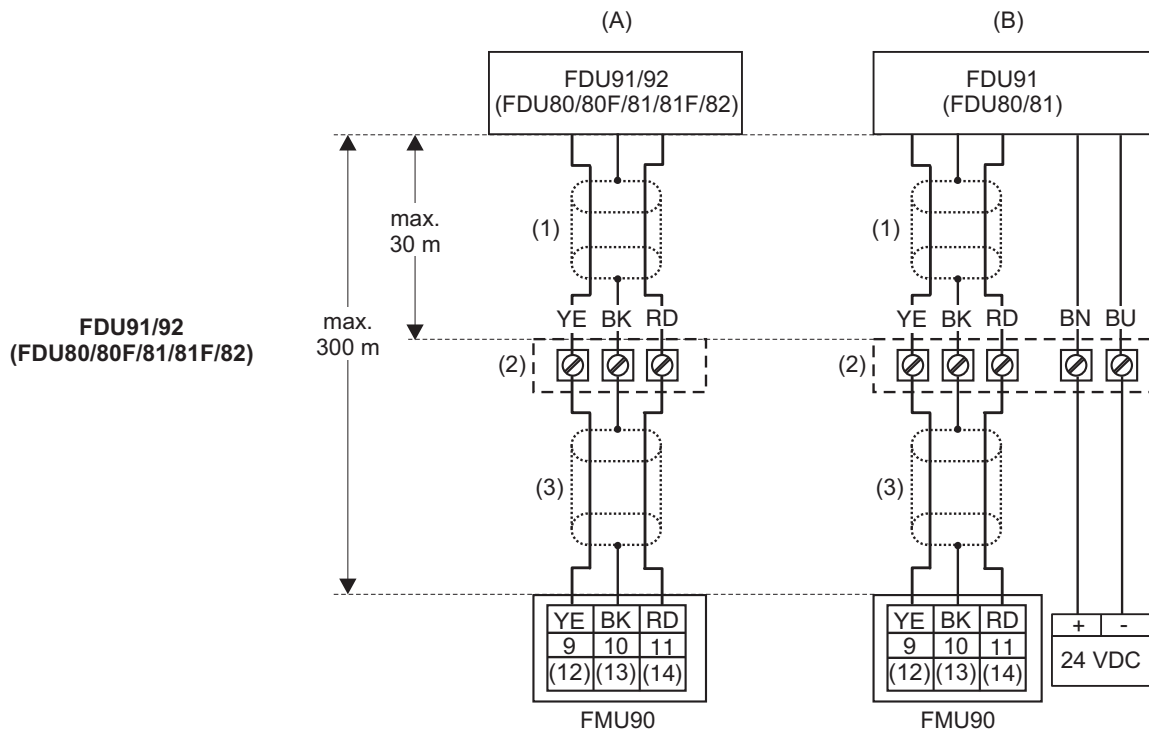

Connect a 4-wire Field Instrument to the HART Input Module

HART communication is active only with current inputs. Connect a 4-wire field instrument to any channel of the 1756-IF8H input module in a 4-wire configuration for current input. This example shows a 4-wire field instrument connected to channel 0.

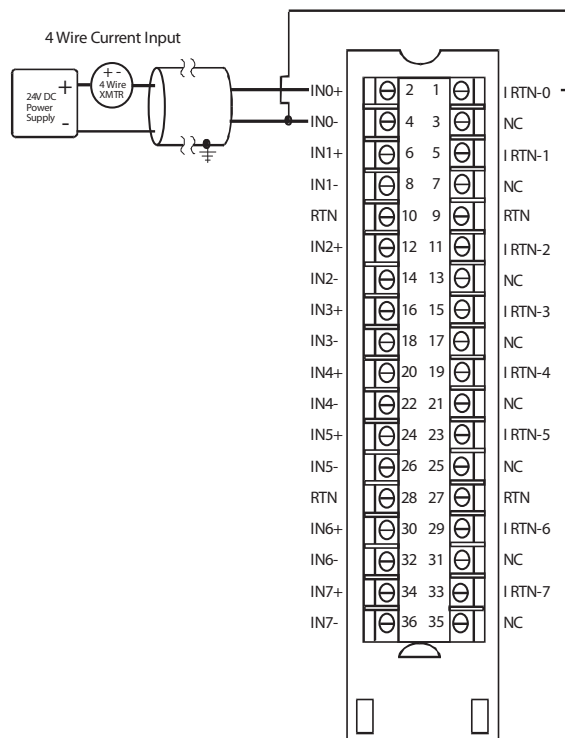

Connect a HART Handheld Device (Optional)

The Field Xpert handheld device communicates with a HART instrument via a VIATOR Bluetooth modem. Communication from the Field Xpert handheld device to the modem is wireless.

WARNING



Do not connect the Field Xpert handheld device to your computer via the USB cable before it is fully charged, as this may damage the device.

1. Charge the battery pack of the Field Xpert device until the battery pack is fully charged (indicated by a red constant LED).
2. Insert the three provided AAA alkaline batteries into the Bluetooth modem.

3. Connect the Field Xpert device by one of these methods:

- Connection across load resistor.

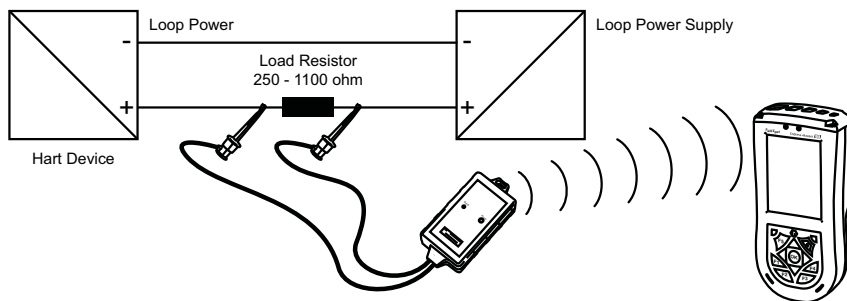

- Connection across RN221N (Ex version).

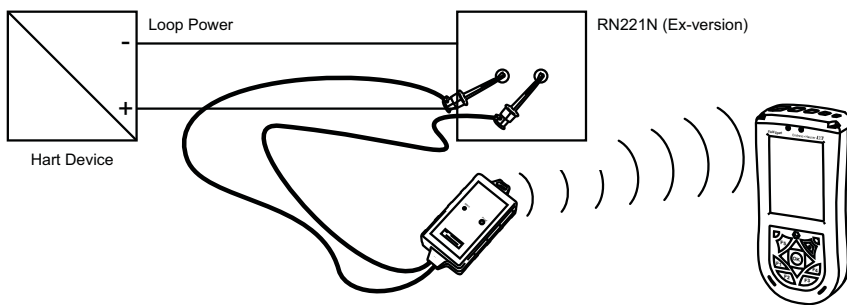

4. Turn power on to both the handheld device and the modem to establish the Bluetooth connection.

Configure the HART Input Module

1. In RSLogix 5000 software, create a new project.
2. In the I/O Configuration tree, right click, New Module.
3. From the Analog Devices list, select 1756-IF8H to open the module properties.
4. On the General tab, Select Analog and HART PV for the Input Data type.

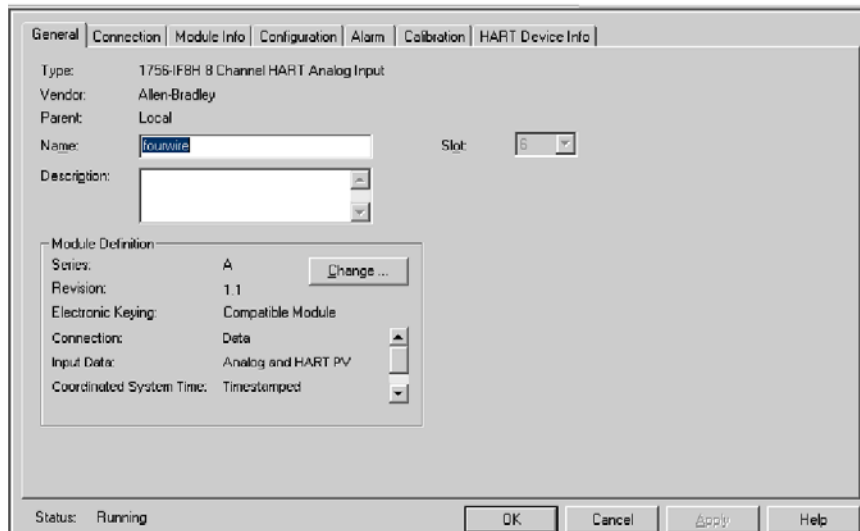

5. On the Configuration tab, enable HART for each channel connected to a HART instrument.

Each channel must be enabled to pass HART data to the controller.

6. Set Pass through to Once per channel scan - the fastest and best for asset management software.

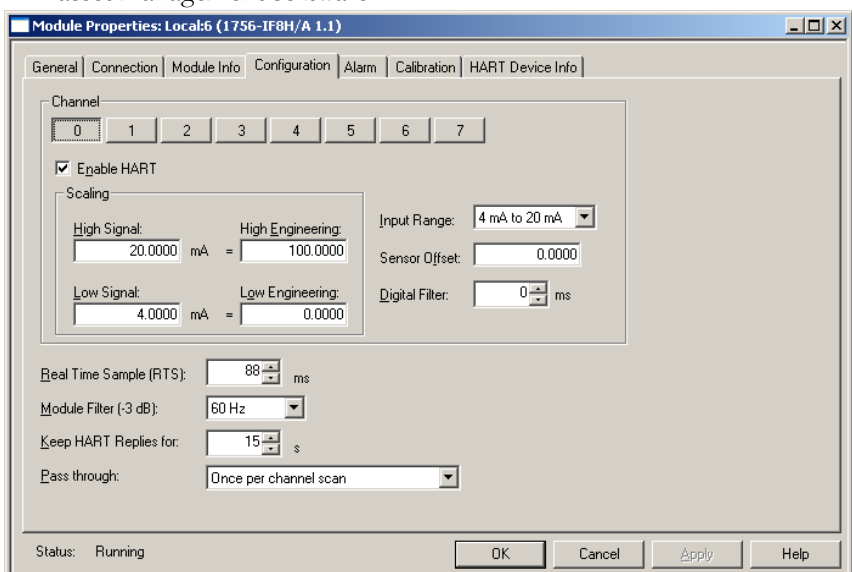

7. Click Apply and then OK.
8. Go to Controller Tags to verify that the tag database was created.
9. Go online with the ControlLogix controller and download the controller project.
10. From the HART Device Info tab in the HART module properties, verify that the instrument is connected.

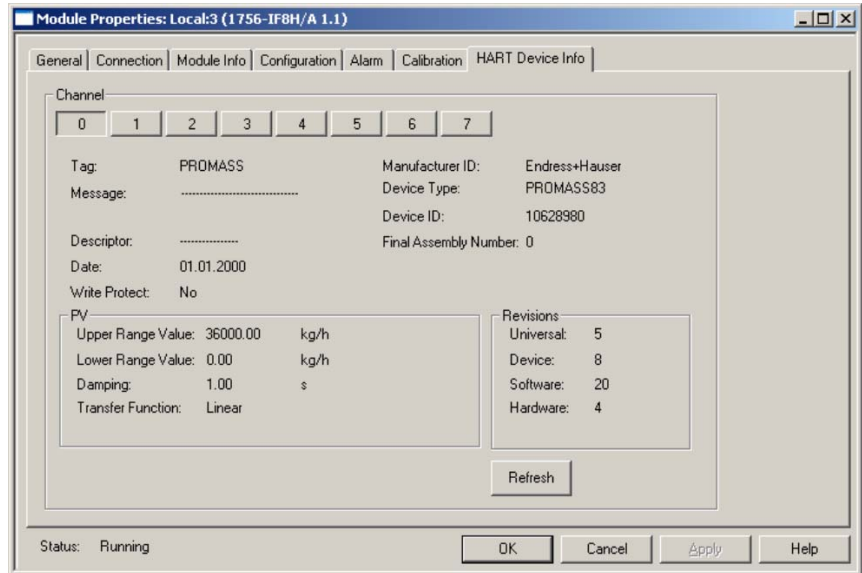

11. Check Controller Tags again to verify that the HART instrument is connected.

A connected instrument will display values in PV, SV, TV, and FV. This tag example shows that the HART input module is in slot 6.

Name	Value	Force Mask	Style	Data Type
Local:6:I.HART.Ch0PV	0.51079947		Float	REAL
Local:6:I.HART.Ch0SV	3.6070764		Float	REAL
Local:6:I.HART.Ch0TV	1.00000005...		Float	REAL
Local:6:I.HART.Ch0FV	24.453247		Float	REAL
Local:6:I.HART.Ch0PVStatus	16#c0		Hex	SINT
Local:6:I.HART.Ch0SVStatus	16#c0		Hex	SINT
Local:6:I.HART.Ch0TVStatus	16#c0		Hex	SINT
Local:6:I.HART.Ch0FVStatus	16#c0		Hex	SINT

Configure the Prosonic S Transmitter

There are several options for configuring the instrument, including the following:

- Local display and menus on the instrument
- HART handheld device
- Asset management software
- CIP messages in controller logic

Configure via Quick Setup Menus on the Local Display

On the local display of the field instrument, use the Quick Setup menus to configure instrument parameters.

Excerpt from the operating menu.
For the complete menu see the Operating Instructions.

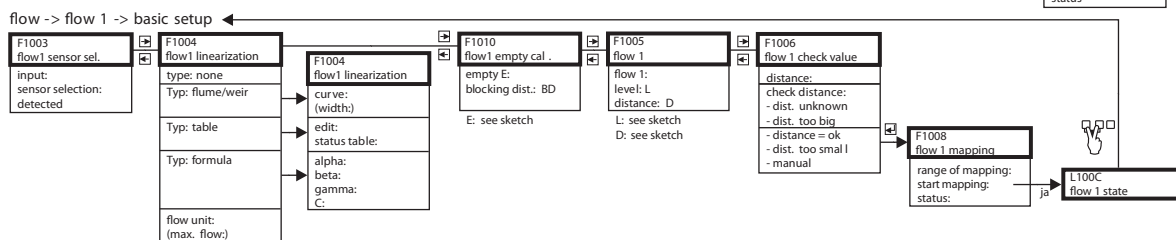
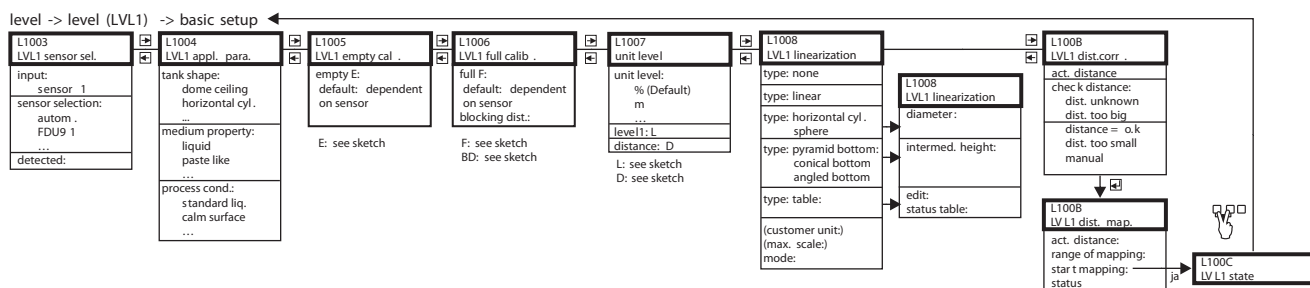

relay/control s -> relay configuration -> see Operating Instructions

device properties

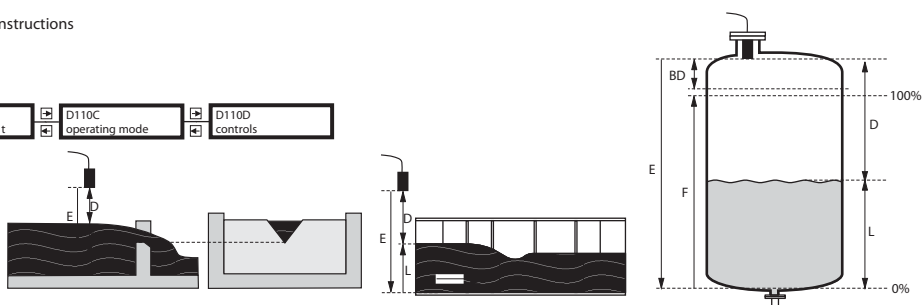
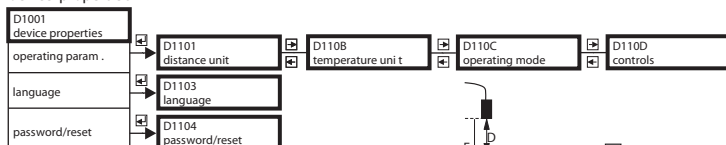

Configure via the HART Handheld Device

Use the Device Xpert configuration software on the handheld device to configure instrument parameters.

1. Open the Device Xpert software and select Device > Scan.

Device Xpert scans the connected network for HART devices and automatically assigns the corresponding device driver (DD) for the found devices.

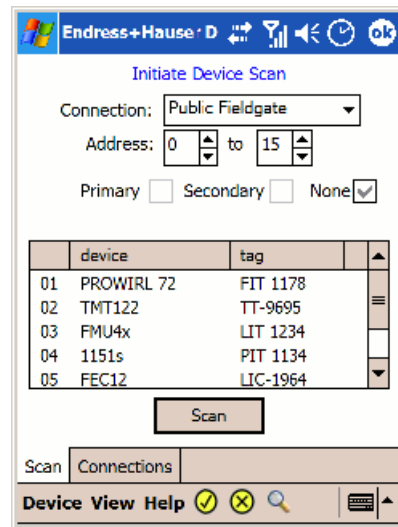

2. Open the device description to configure the parameters you need.
3. When you finish the configuration, select the check mark at the bottom to write the changes into the field device.

The handheld also supports special device functions, such as envelope curves and automatic distribution and update of device descriptions.

- To open the envelope curve, select Device > Enable Device Extensions and activate the envelope curve.

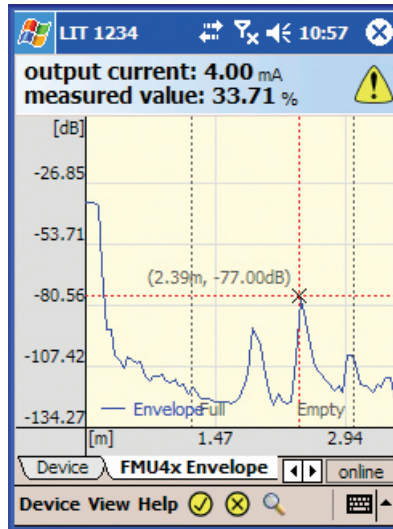

- For an automatic update of the device description, the handheld device must be connected via WiFi or USB and a computer to the Internet. Select Device > Synchronize Library to update the device description.

The handheld device includes the following other functions:

- Device diagnostics
- Search functions
- Application help
- Favorites folder

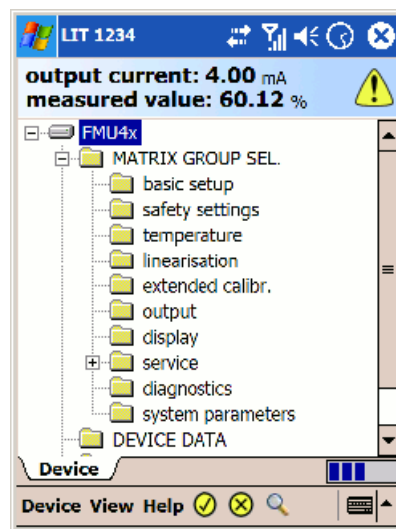

Configure via FieldCare Software

FieldCare is the Endress+Hauser FDT-based plant asset management tool that lets you configure intelligent field instruments.

1. Start FieldCare and open a new project.

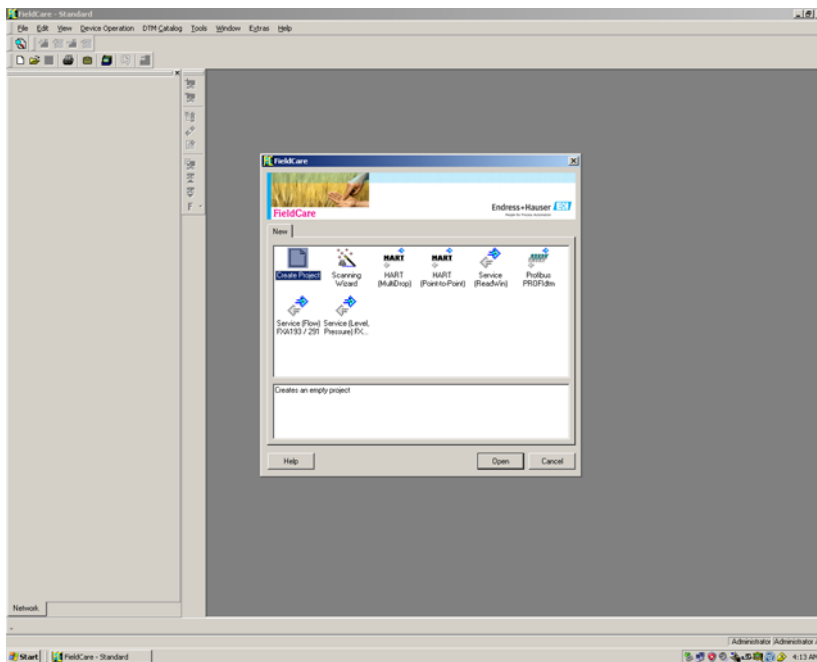

IMPORTANT

To optimize FieldCare performance, it is recommended that you verify that the correct DTMs are loaded in the catalog.

2. Choose the DTM Catalog menu and click Update.

- If there are DTMs listed in the dialog box's left pane, select desired DTMs and click Move.

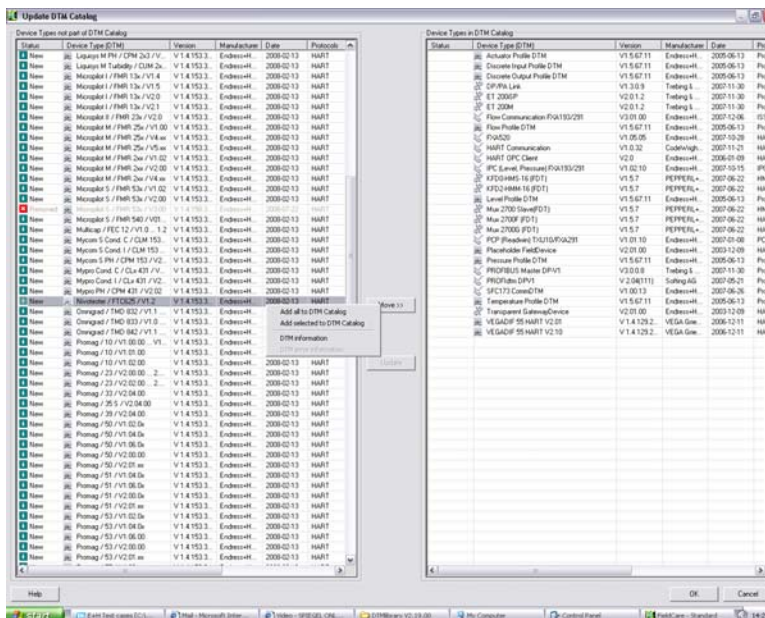

If you do not find the desired DTMs, or if the left pane of the dialog box is empty, click Update. FieldCare searches for DTMs installed on your computer. After the search, found DTMs are added to the dialog box's left pane.

If necessary, to remove DTMs, select the desired DTMs in the right pane and click Move.

- Click OK to save your changes.

- From the Device Operation/Add Device menu, select the RSLinx 1756 Backplane and click OK.

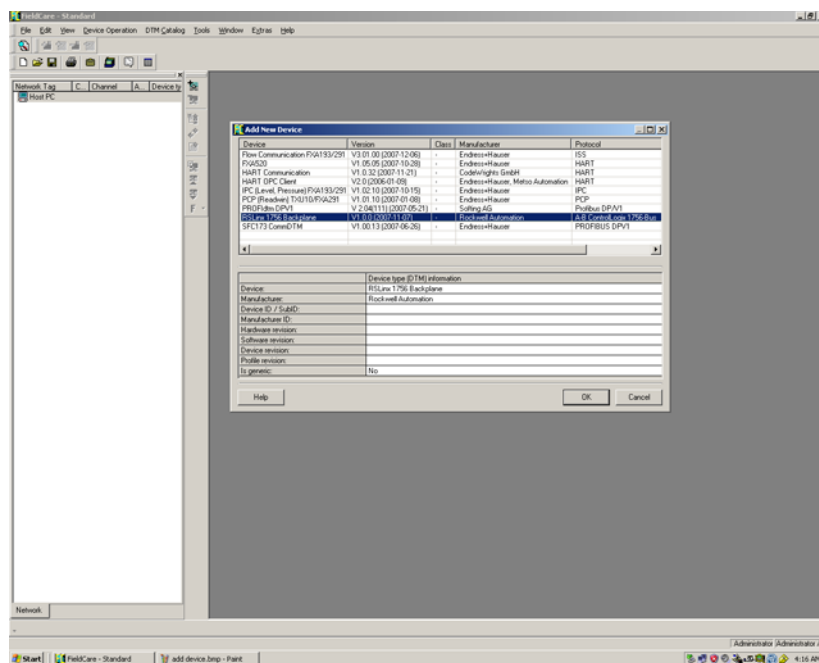

- To configure the RSLinx backplane, double-click on the RSLinx backplane in the left pane.
- Click Select Path and drill down to the ControlLogix backplane.

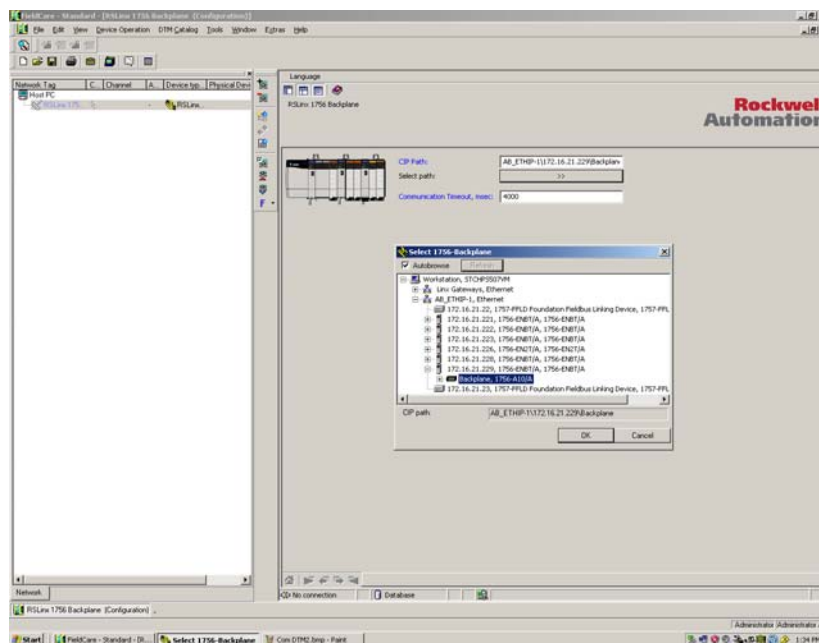

8. From the Device Operation/Add Device menu, select the 1756-IF8H/A module and click OK.

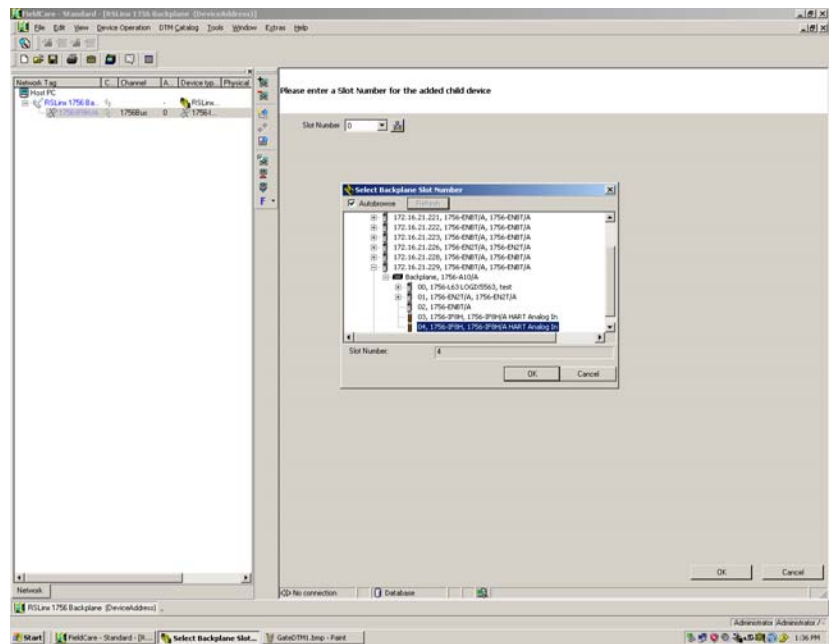

9. To configure the 1756-IF8H module, double-click on the module backplane in the left pane.
10. Enter the slot number and click the Create Network icon.
11. When prompted, click OK.

The Com DTM now scans the entire HART network behind the multiplexer and searches for the right DTM.

If the right DTM is installed, the instrument comes up in the Explorer view on the left side.

IMPORTANT

If only one DTM is added to the network, the software automatically goes online. Otherwise a warning occurs that must be confirmed. To switch this behavior off, in the Fieldcare-context-menu Extras/Options, select After Scanning within page Scanning.

Access Instrument Data

You can use FieldCare software to access instrument data.

The following examples show a Promass field instrument. Your screens may vary depending on the field instrument.

1. In an open FieldCare project, right-click on the instrument in the left pane and select Connect.
2. Double-click on the instrument in the left pane.
3. In the Online pane, select Device Data.

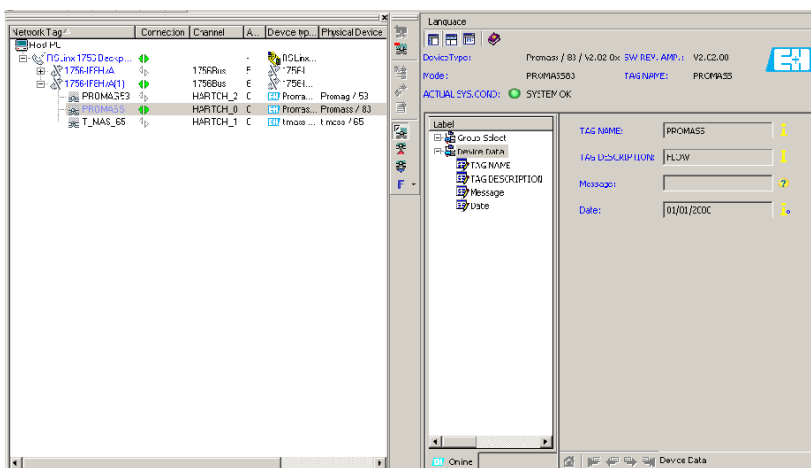

4. To view measured values, right-click on the instrument in the left pane and choose Observe.

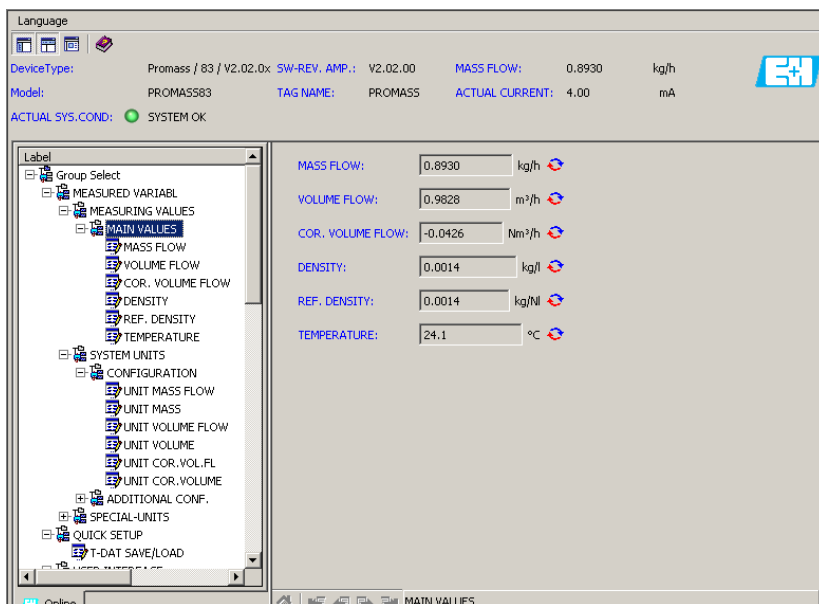

Additional Functions

You can use FieldCare software to perform these additional functions:

- Toggle between connected and disconnected modes
- Read from device
- Write to device
- Device-specific functions

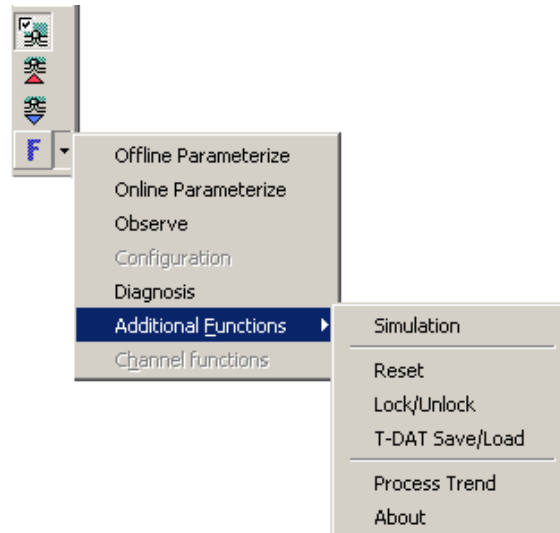

Configure via CIP Messages

CIP message instructions let you access the following additional HART instrument parameters:

- Universal Command 3
- Command 35 (PV range)
- Command 40 (simulate output current of primary PV)
- Command 44 (PV units)
- Command 48 diagnostic information

See [Additional Resources](#) on page 31 for more information about accessing HART instrument parameters.

Visualization

To use the predesigned faceplates to monitor the instrument, HART must be enabled for the 1756-IF8H module. FactoryTalk View SE faceplates provide for visualization of instruments connected to a 1756-IF8H module. The 1756-IF8H module provides the necessary data to the faceplates.

The following information summarizes the Add-On Instructions and faceplates. See [Additional Resources](#) on page 31 for more detailed information.

Add-On Instructions

There are three, pre-designed Add-On Instructions that provide a two-way exchange of data between the faceplates and the ControlLogix controller. The name of the specific instance of the Add-On Instruction becomes the link from the actual instrument to the faceplate on the graphic.

- Structured input data for each 1756-IF8H module.

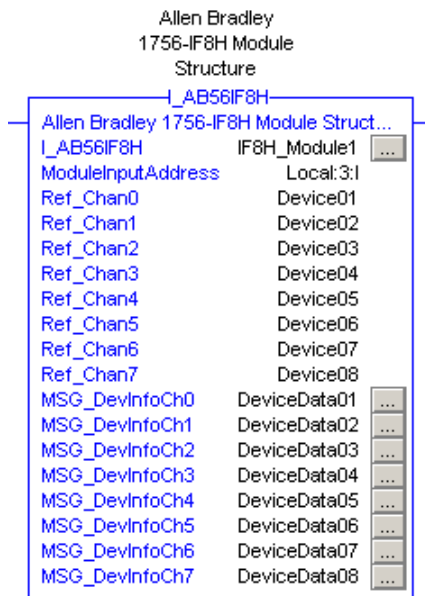

- Structured data for each instrument.

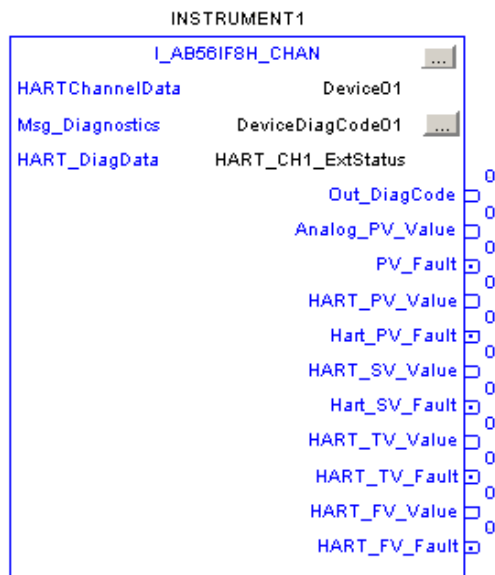

- Send the analog and process variable values from each instrument to one or more faceplates.

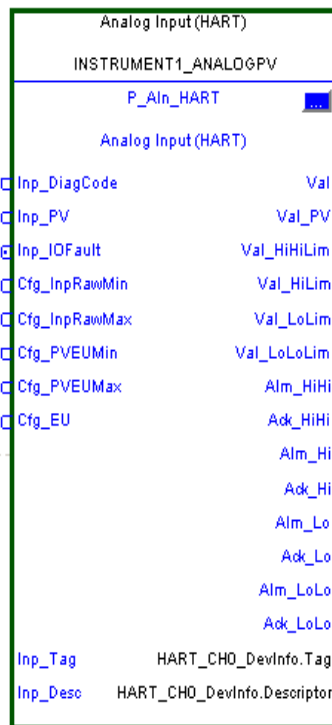

IMPORTANT

The P_Aln_HART Add-On Instruction uses embedded P_MODE and P_ALARM Add-On Instructions. These embedded Add-On Instructions must already be in the project before importing the P_Aln_HART Add-On Instruction.

Global Object

A global object links the tag name to the faceplate, provides a touch area for the faceplate to be launched from, and displays the process variables and alarms.

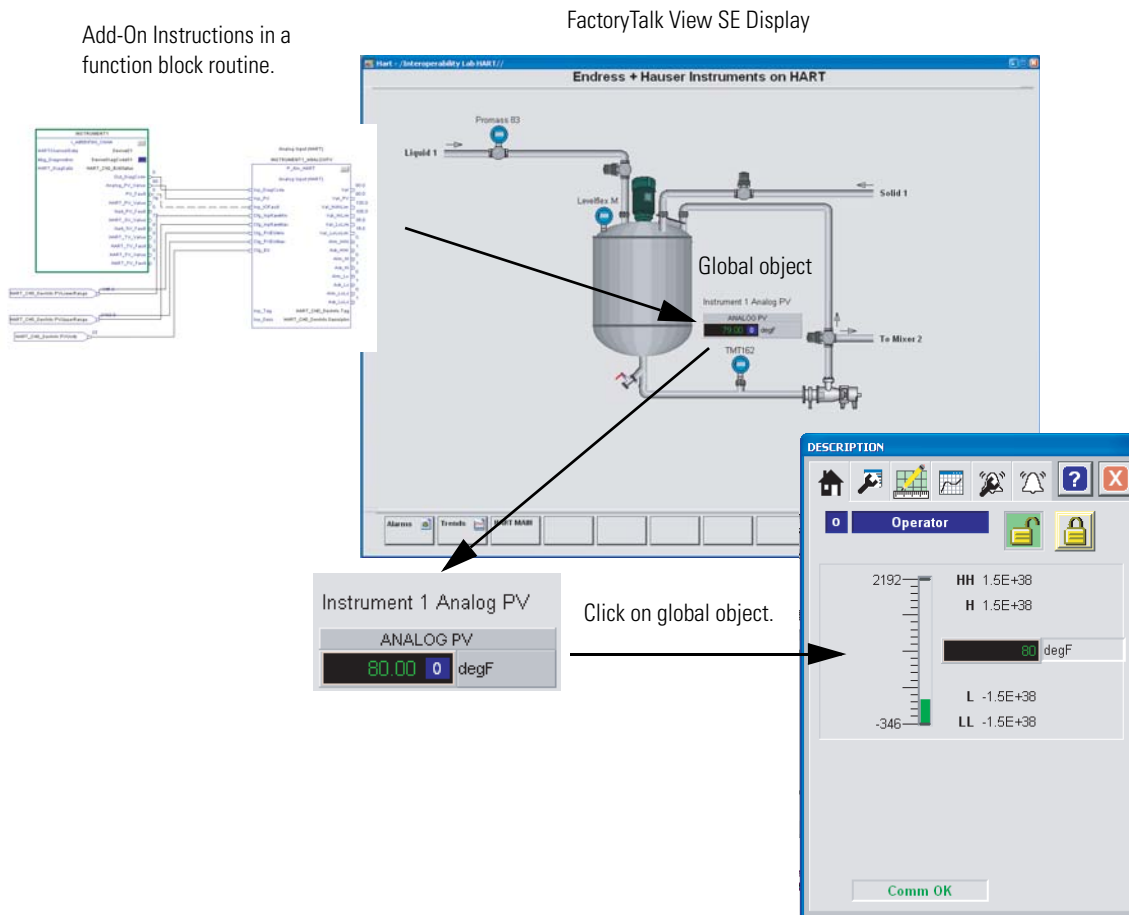

IMPORTANT

A unique global object and faceplates are available for each field instrument due to the display of instrument-specific diagnostic information.

Faceplates

The FactoryTalk View SE generic display provides a graphical representation of the instrument based on the information contained within each Add-On Instruction. Navigation buttons at the top of the faceplate change the information displayed. Status displays show information using a bar graph, numeric values, and a trend display. Other displays show specific alarms and warning indication.

Here are some examples of predesigned faceplates.

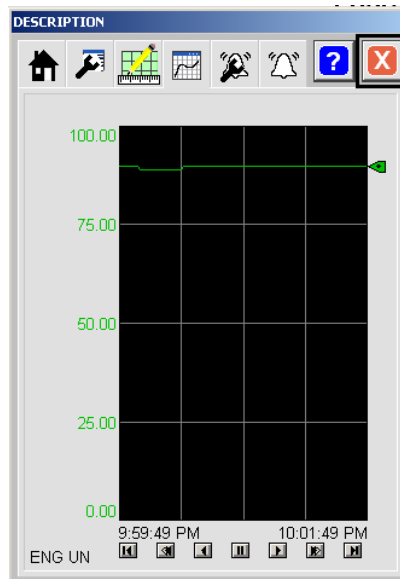
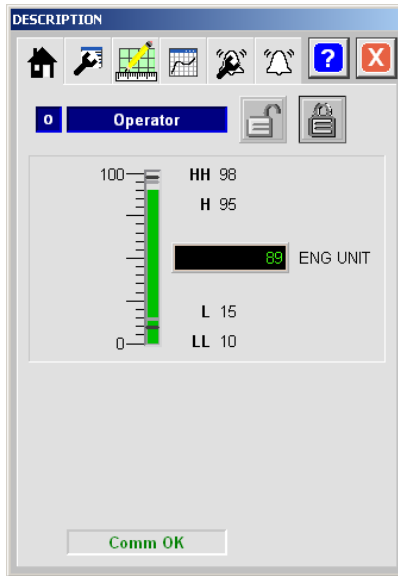
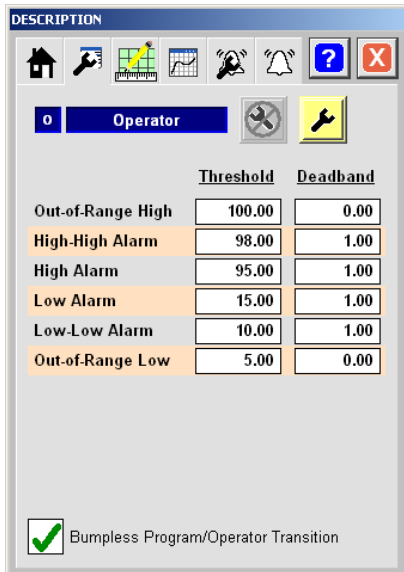
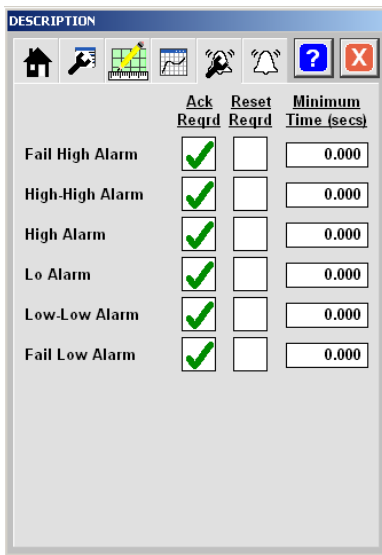
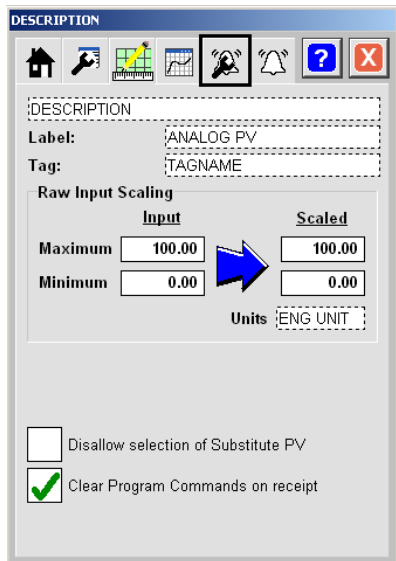

IMPORTANT

A unique global object and faceplates are available for each field instrument due to the display of instrument-specific diagnostic information.

The faceplates provide the following information:

- Tag name from instrument
- Description from instrument
- Engineering units from instrument
- Typical analog process values (PV)
- Analog fault status (channel fault, broken wire, module fault)
- HART PV (first, second, third)
- HART PV fault status (first, second, third, fourth)
- HART PV range (minimum and maximum)
- HART command 48 diagnostic information

Configure the faceplates to provide the following:

- Mode (such as operator or program)
- High-high, high, low, and low-low alarms
- Over-range and under-range alarms
- Alarm delay
- Alarm hysteresis

Diagnostic Messages

Command 48 provides information about an instrument when an instrument's transmitter or sensor is not running properly. Command 48 produces a byte and bit based output that can be translated into specific error codes that can help maintenance personnel determine more specific details about abnormal conditions with HART instruments.

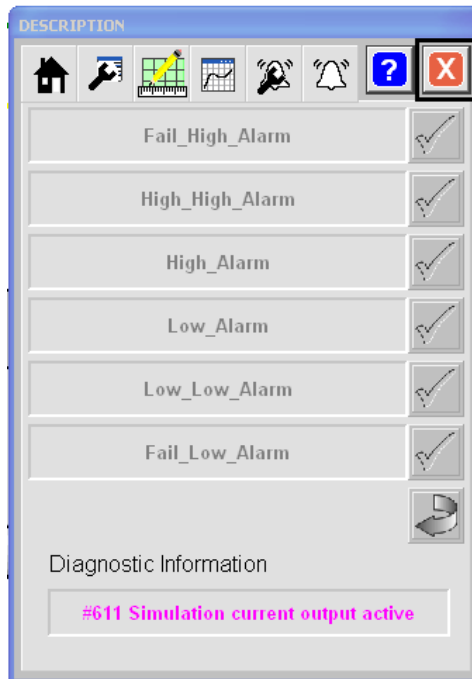

Performance Considerations

Keep in mind these considerations when integrating HART instruments:

- The HART communication protocol has a relatively slow baud rate at 1200/2400 bits per second.
- The 1756-IF8H HART module executes one HART command per instrument at a time. Analog (4-20ma) data are delivered from all channels simultaneously.
- The time of execution for Universal Command 3 is estimated from 200...600 ms, but varies based on the complexity and response time of the instrument.
- Upload and download time of instrument parameters to and from FieldCare software can take several minutes depending on the instrument.

Additional Resources

Resource	Description
HART Field Instruments	
Prosonic S FMU90 Technical Information, publication TI397F/00/en	Specifications and details of the Prosonic S FMU90 ultrasonic level device.
Prosonic S FMU90 Flow Operating Instructions (HART), publication BA289F/00/en	How to install, wire, configure, and operate a Prosonic S FMU90 transmitter for flow measurement.
Prosonic S FMU90 Level Operating Instructions (HART), publication BA288F/00/en	How to install, wire, configure, and operate a Prosonic S FMU90 transmitter for level measurement.
Field Xpert Device Configurator Operating Instructions, publication BA060S/04/en	How to use the Field Xpert handheld device to configure Endress+Hauser instruments.
Control System Components	
ControlLogix Controllers Installation Instructions, publication 1756-IN101	How to install and configure a ControlLogix controller.
ControlLogix Controllers User Manual, publication 1756-UM001	How to configure, operate, and maintain a ControlLogix controller.
ControlLogix Analog HART Input Module Installation Instructions, publication 1756-IN608	How to install and 1756-IF8H input module.
ControlLogix Analog HART I/O Modules User Manual, publication 1756-UM533	How to configure, operate, and maintain a 1756-IF8H input module.
Accessing HART Device Parameters using CIP Messages, Knowledgebase document (Login required. Please contact your sales representative.)	How to use MSG instructions in controller logic to access instrument parameters.
Operator Components	
Add-On Instructions and Faceplates for Visualizing HART Instrument Data in FactoryTalk View SE, Knowledgebase document (Login required. Please contact your sales representative.)	How to implement the HART Add-On-Instruction in controller logic to work with the FactoryTalk View faceplates for HART instruments.
FactoryTalk View Site Edition User's Guide Volume 1, publication VIEWSE-UM004	How to design, develop, and deploy FactoryTalk View SE applications.
FactoryTalk View Site Edition User's Guide Volume 2, publication VIEWSE-UM005	
Faceplates, Add-On Instructions, project files, etc. (Login required. Please contact your sales representative.)	Download AOIs, Faceplates and Global Object graphics, and project files.
www.products.endress.com/fieldcare	Information about FieldCare Asset Management software.
www.products.endress.com/dtm-download	Information about field instrument DTMs.
Process Control Information	
Integrated Architecture for Process Control System Recommendations Manual, publication PROCES-RM001	Process system recommendations that organize Rockwell Automation products functionally as system elements, which can then be applied in proven, scalable configurations for continuous and batch control.
http://www.rockwellautomation.com/process	Information about Rockwell Automation process control and Integration Documents.
http://literature.rockwellautomation.com	Available Rockwell Automation publications, including Integration Documents.
http://www.endress.com	Information about Endress+Hauser field instruments.

Rockwell Automation Support

Rockwell Automation provides technical information on the Web to assist you in using its products. At <http://support.rockwellautomation.com>, you can find technical manuals, a knowledge base of FAQs, technical and application notes, sample code and links to software service packs, and a MySupport feature that you can customize to make the best use of these tools.

For an additional level of technical phone support for installation, configuration, and troubleshooting, we offer TechConnect support programs. For more information, contact your local distributor or Rockwell Automation representative, or visit <http://support.rockwellautomation.com>.

Endress+Hauser Support

Please refer to your local Endress+Hauser Sales Center for precise information regarding the service support available in your area or visit <http://www.endress.com>.

Installation Assistance

If you experience a problem within the first 24 hours of installation, please review the information that's contained in this manual. You can also contact a special Customer Support number for initial help in getting your product up and running.

United States	1.440.646.3434 Monday – Friday, 8 a.m. – 5 p.m. EST
Outside United States	Please contact your local Rockwell Automation representative for any technical support issues.

New Product Satisfaction Return

Rockwell Automation tests all of its products to ensure that they are fully operational when shipped from the manufacturing facility. However, if your product is not functioning and needs to be returned, follow these procedures.

United States	Contact your distributor. You must provide a Customer Support case number (call the phone number above to obtain one) to your distributor in order to complete the return process.
Outside United States	Please contact your local Rockwell Automation representative for the return procedure.

Allen-Bradley, ControlLogix, FactoryTalk, PlantPAx, Rockwell Automation, RSLinx, RSLogix 5000, and TechConnect are trademarks of Rockwell Automation, Inc. Trademarks not belonging to Rockwell Automation are property of their respective companies.

Endress+Hauser is trusted by more than 100,000 customers to make their processes safe, efficient and environmentally friendly. We offer a range of measurement products, including level, flow, pressure, temperature, analytical and complete engineered solutions designed to help customers acquire, transmit, control and record process information needed to manage operations in a safe, reliable and profitable manner.

www.endress.com/worldwide

International:

Endress+Hauser
Instruments International
Kaegenstr. 2, CH-4153 Reinach/BL,
Switzerland
Tel: +41 61 715 81 00
Fax: +41 61 715 25

USA:

Endress+Hauser, Inc.
2350 Endress Place
Greenwood, IN 46143
Tel: (1) 317 535 7138
Fax: (1) 317 535 8498

Canada:

Endress+Hauser, Canada
1075 Sutton Drive
Burlington, ON L7L 5Z8
Tel: (1) 905 681 9292
Fax: (1) 905 681 9444

Mexico:

Endress+Hauser México, S.A. de C.V.
Fernando Montes de Oca 21 Edif A Piso3
San Nicolás, 54030 Tlalnepantla,
Edo de México
Tel: +52 55 5321 2080
Fax: +52 55 5321 2099

Rockwell Automation, Inc. (NYSE: ROK) is a leading global provider of industrial automation power, control and information solutions that help manufacturers achieve a competitive advantage in their businesses. The company brings together leading global brands in industrial automation which include Allen-Bradley controls and services and Rockwell Software factory management software.

www.rockwellautomation.com/solutions/process

Americas:

Rockwell Automation
1201 South Second Street,
Milwaukee, WI 53204-2496 USA
Tel: (1) 414 382 2000
Fax: (1) 414 382 4444

Europe/Middle East/ Africa:

Rockwell Automation
Vorstaan/Boulevard du Souverain 36,
1170 Brussels, Belgium
Tel: +32 2 663 0600
Fax: +32 2 663 0640

Asia Pacific:

Rockwell Automation
Level 14, Core F, Cyberport 3,
100 Cyberport Road, Hong Kong
Tel: +852 2887 4788
Fax: +852 2508 1846